

Universal Oven Um UF110mplus

The heating oven Um is a Class I medical device.

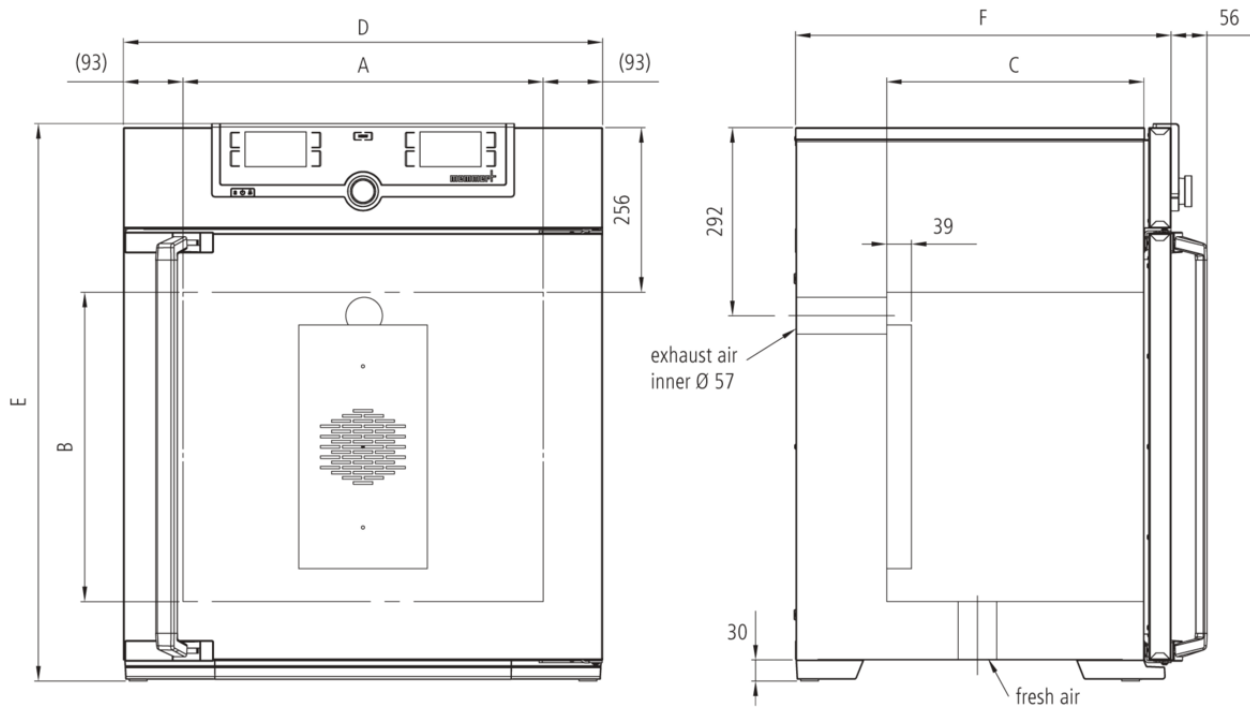

This universal oven made of high-quality hygienic, easy to clean stainless steel leaves nothing to be desired in terms of ventilation technology, control technology, overtemperature protection and perfectly tuned heating technology.



Temperature

| | |
|-------------------------------------|--|
| Working temperature range | at least 5 (UN/UNplus/UNm/UNmplus) or 10 (UF/UFplus/UFm/UFmplus) above ambient temperature to +300 °C |
| Setting accuracy temperature | up to 99.9 °C: 0.1 / from 100 °C: 0.5 |
| Setting temperature range | +20 to +300 °C |
| Temperature sensor | 2 Pt100 sensors DIN Class A in 4-wire-circuit for mutual monitoring, taking over functions in case of an error |

Control technology

| | |
|------------------------------|---|
| ControlCOCKPIT | TwinDISPLAY. Adaptive multifunctional digital PID-microprocessor controller with 2 high-definition TFT-colour displays. |
| Language setting | German, English, Spanish, French, Polish, Czech, Hungarian |
| Timer | Digital backwards counter with target time setting, adjustable from 1 minute to 99 days |
| Function HeatBALANCE | adapting the distribution of the heating performance of the upper and lower heating circuit from -50 % to +50 % |
| Function SetpointWAIT | the process time does not start until the set temperature is reached |
| Calibration | three freely selectable temperature values |
| adjustable parameters | temperature (Celsius or Fahrenheit), fan speed, air flap position, programme time, time zones, summertime/wintertime |

Ventilation

| | |
|----------------------------|--|
| Fan | forced air circulation by quite air turbine, adjustable in 10 % steps for each segment individually |
| Fresh air admixture | adjustment of pre-heated fresh air admixture by air flap control in 10 % steps for each segment individually |
| Vent | vent connection with restrictor flap |

Communication

| | |
|----------------------|--|
| Documentation | programme stored in case of power failure |
| Programming | AtmoCONTROL software on a USB stick for programming, managing and transferring programmes via Ethernet interface or USB port |

Safety

| | |
|------------------------------|--|
| Temperature control | mechanical temperature limiter TB, protection class 1 according to DIN 12880 to switch off the heating approx. 20°C above nominal temperature |
| Temperature control | overtemperature monitor TWW, protection class 3.1 or adjustable temperature limiter TWB, protection class 2, selectable on display |
| AutoSAFETY | additionally integrated over- and undertemperature monitor "ASF", automatically following the setpoint value at a preset tolerance range, alarm in case of over- or undertemperature, heating is switched off in case of overtemperature |
| Autodiagnostic system | for fault analysis |
| Alarm | visual and acoustic |

Standard equipment

| | |
|--------------------------------------|---|
| Door | fully insulated stainless steel door with 2-point locking (compression door lock) |
| Internals | 2 stainless steel grid(s), electropolished |
| Works calibration certificate | Calibration at +160°C |

Stainless steel interior

| | |
|----------------------------------|--|
| Dimensions | $w_{(A)} \times h_{(B)} \times d_{(C)}$: 560 x 480 x 400 mm (d less 39 mm for fan) |
| Interior | easy-to-clean interior, made of stainless steel, reinforced by deep drawn ribbing with integrated and protected large-area heating on four sides |
| Volume | 108 l |
| Max. number of internals | 5 |
| Max. loading of chamber | 175 kg |
| Max. loading per internal | 20 kg |

Textured stainless steel casing

| | |
|-------------------|--|
| Dimensions | $w_{(D)} \times h_{(E)} \times d_{(F)}$: 745 x 864 x 584 mm (d +56mm door handle) |
| Housing | rear zinc-plated steel |

Electrical data

| | |
|------------------------|-----------------|
| Voltage | 230 V, 50/60 Hz |
| Electrical load | approx. 2800 W |
| Voltage | 115 V, 50/60 Hz |
| Electrical load | approx. 1800 W |

Ambient conditions

| | |
|---------------------------------|---|
| Set Up | The distance between the wall and the rear of the appliance must be at least 15 cm. The clearance from the ceiling must not be less than 20 cm and the side clearance from walls or nearby appliances must not be less than 5 cm. |
| Altitude of installation | max. 2,000 m above sea level |
| Ambient temperature | +5 °C to +40 °C |
| Humidity rh | max. 80 %, non-condensing |
| Overvoltage category | II |
| Pollution degree | 2 |

Packing/shipping data

| | |
|---------------------------------------|--|
| Transport information | The appliances must be transported upright |
| Customs tariff number | 8419 8998 |
| Country of origin | Federal Republic of Germany |
| WEEE-Reg.-No. | DE 66812464 |
| Dimensions approx incl. carton | w x h x d: 830 x 1050 x 800 mm |
| Net weight | approx. 74 kg |
| Gross weight carton | approx. 99 kg |

Standard units are safety-approved and bear the test marks

